

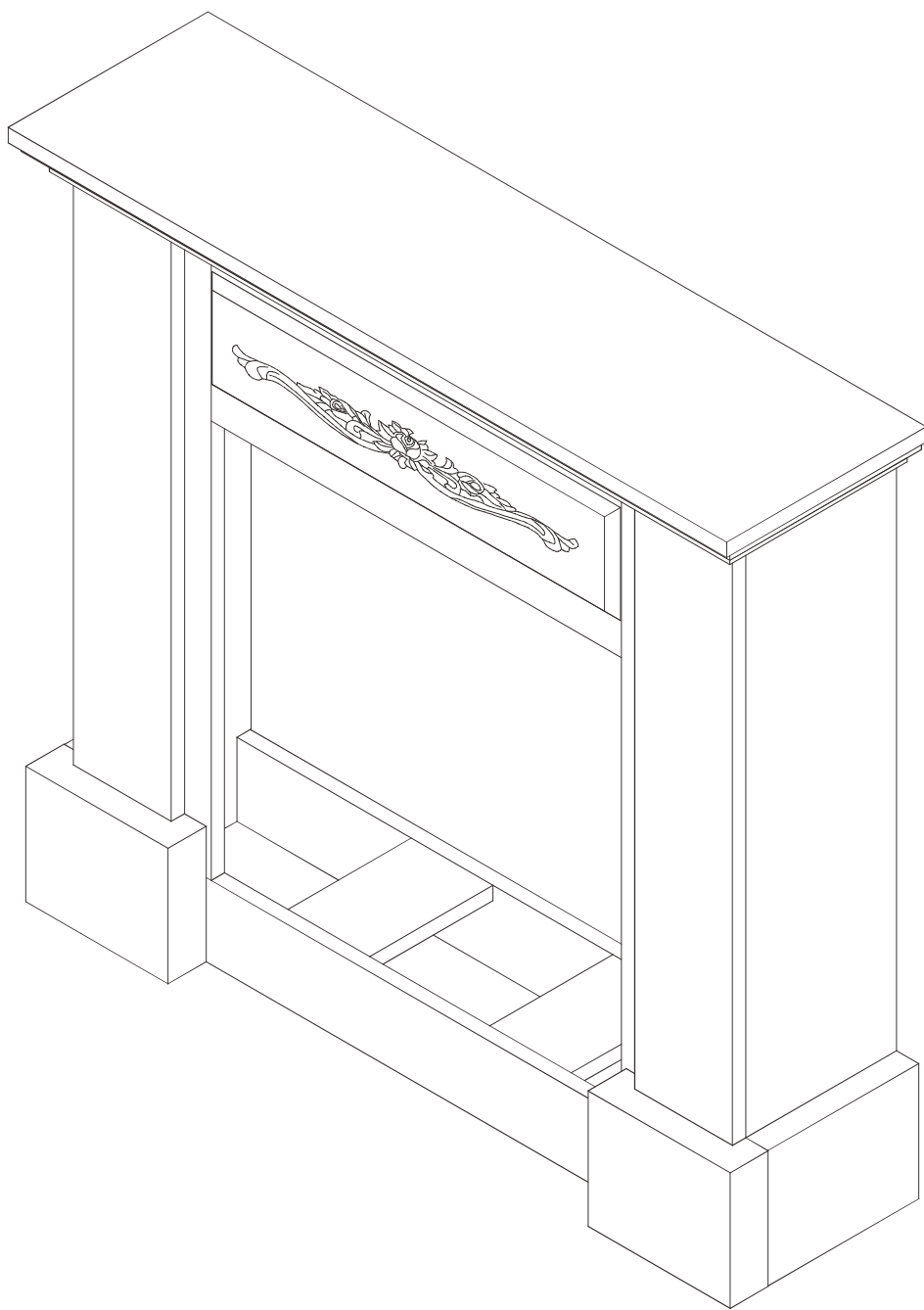







ASSEMBLY STEPS

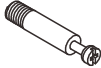

PART IDENTIFICATION:

| CODE | DESCRIPTION | QTY |
|------|-------------------|-----|
| 1 | Top Panel | 1 |
| 2 | Front Up Panel | 1 |
| 3 | Front Base Panel | 1 |
| 4 | Back Base Panel | 1 |
| 5 | Left Side Panel | 1 |
| 6 | Right Side Panel | 1 |
| 7 | Left Front Panel | 1 |
| 8 | Right Front Panel | 1 |
| 9 | Left Trim Panel | 1 |
| 10 | Right Trim Panel | 1 |
| 11 | Left Foot Panel | 1 |
| 12 | Right Foot Panel | 1 |
| 13 | Case Panel | 2 |

Hardware Parts List:

| CODE | PICTURE | DESCRIPTION | QTY |
|------|---|---|-----|
| A |  | Bolt | 16 |
| B |  | Plastic Connector | 8 |
| C |  | Metal Dowel | 10 |
| D |  | Metal Cam | 10 |
| E |  | Wood Dowel | 26 |
| F |  | Screw | 19 |
| G |  | Metal Connector | 2 |
| H |  | Plastic Cap | 10 |
| J |  | Touch-up pen (Please use the enclosed touch-up pen so instantly cover nicks and scratches on the surface and edges.) | 1 |

Assembly Tools Required:



OR





OR

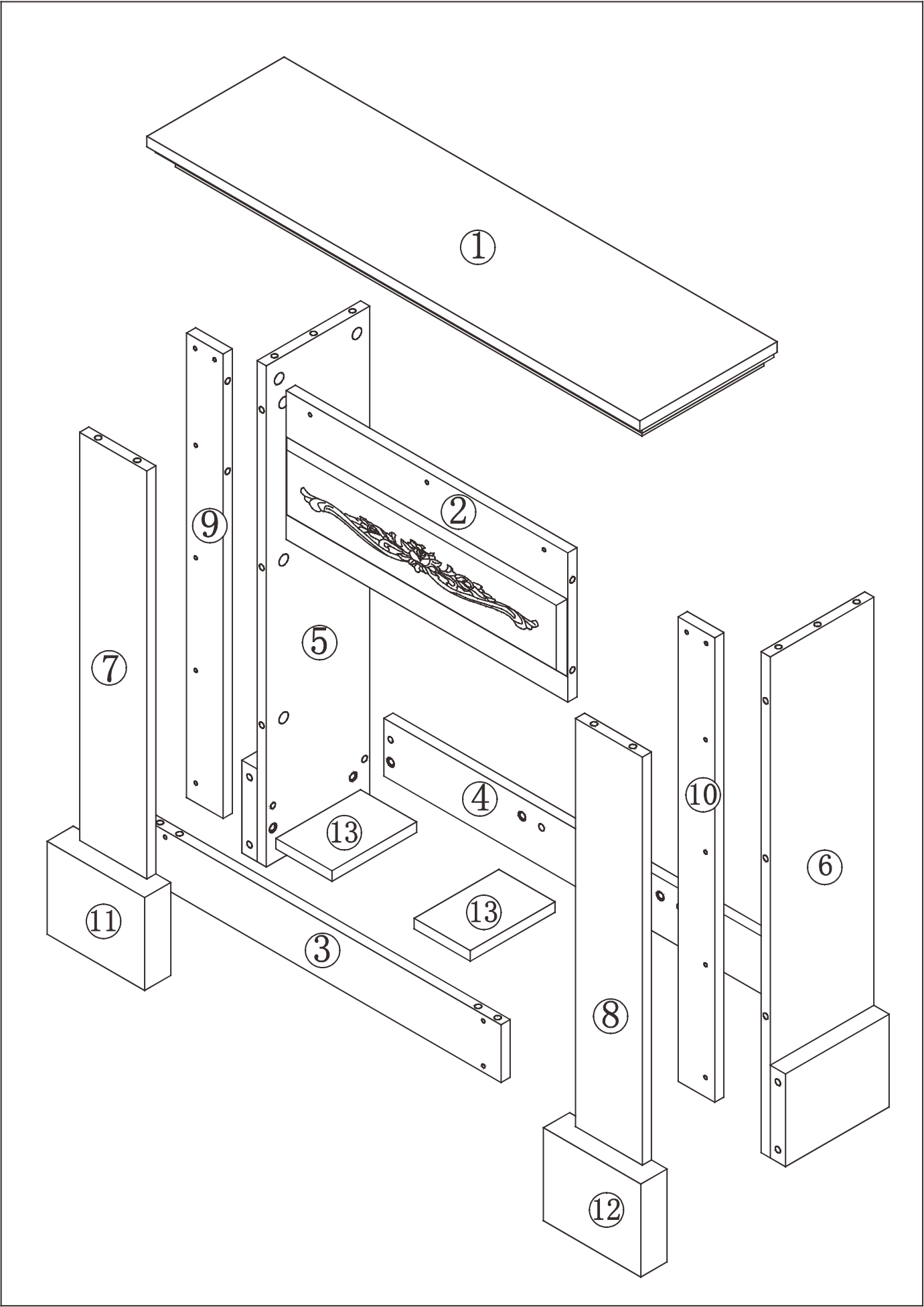



STEP 1

| | | |
|---|---|---|
| A |  | 8 |
| B |  | 8 |

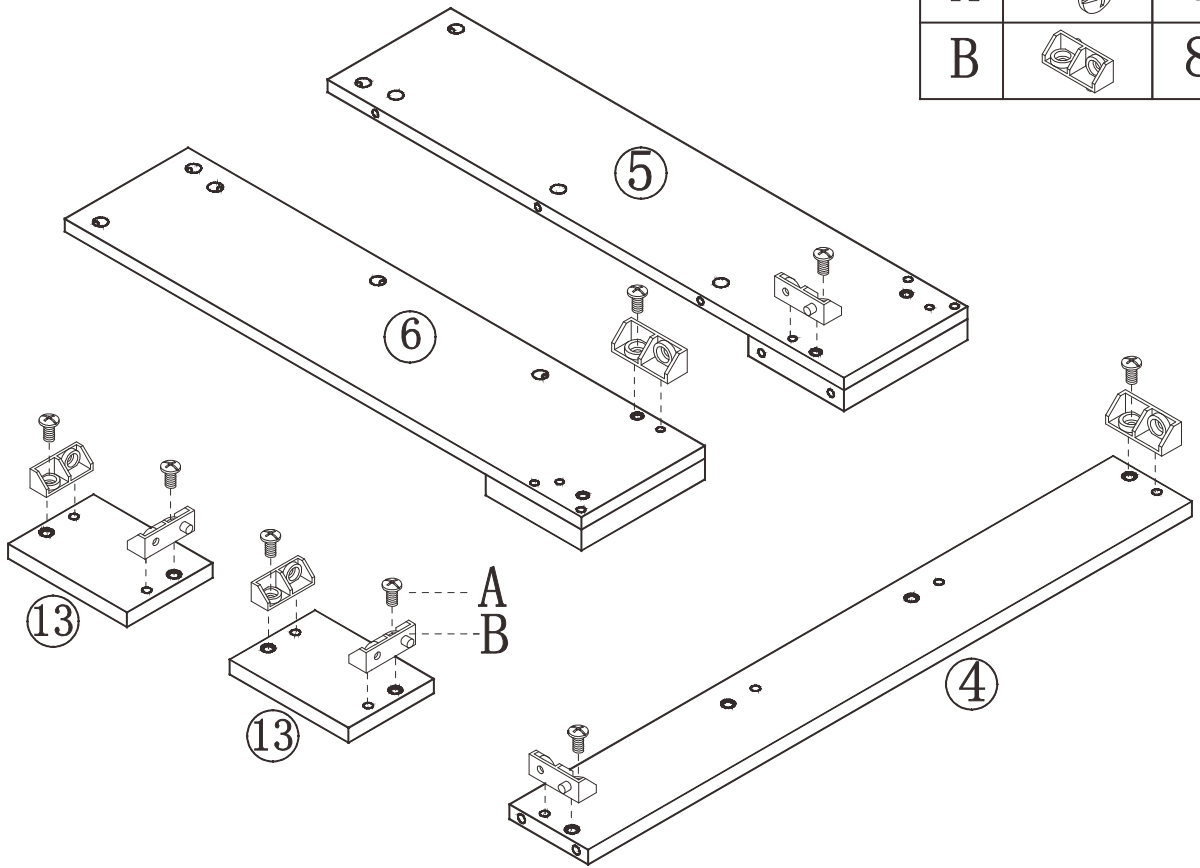

STEP 2

| | | |
|---|---|---|
| A |  | 2 |
|---|---|---|

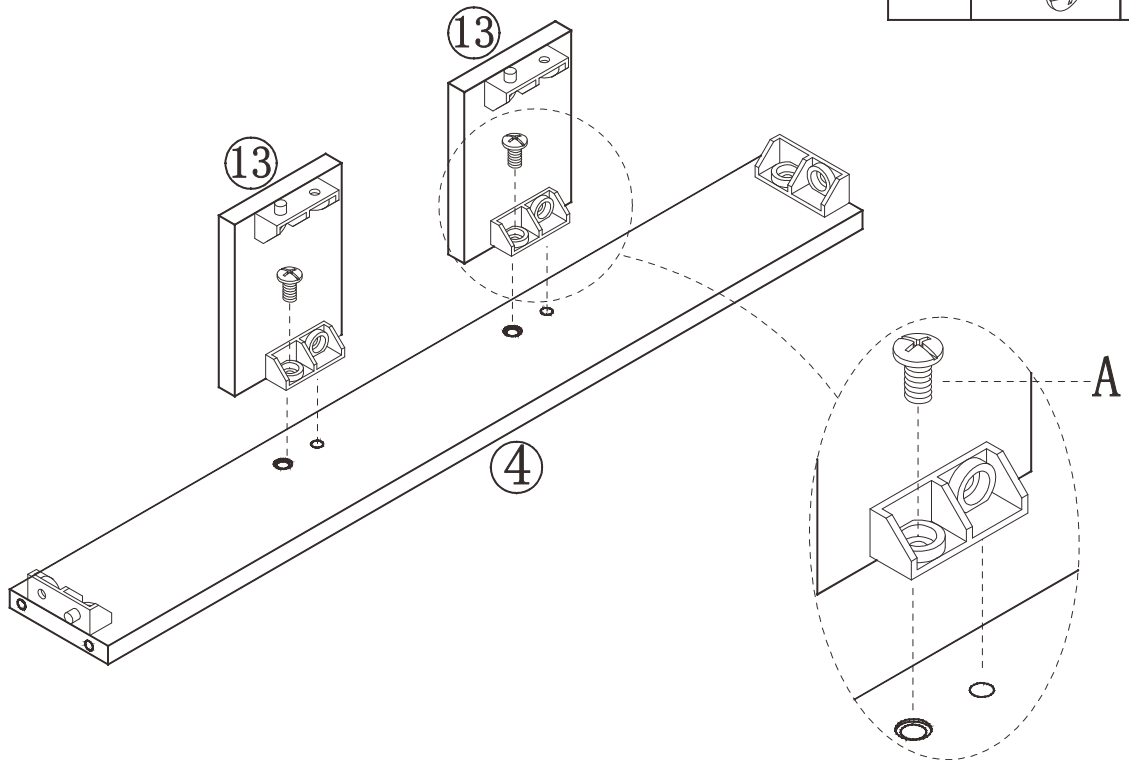

STEP 3

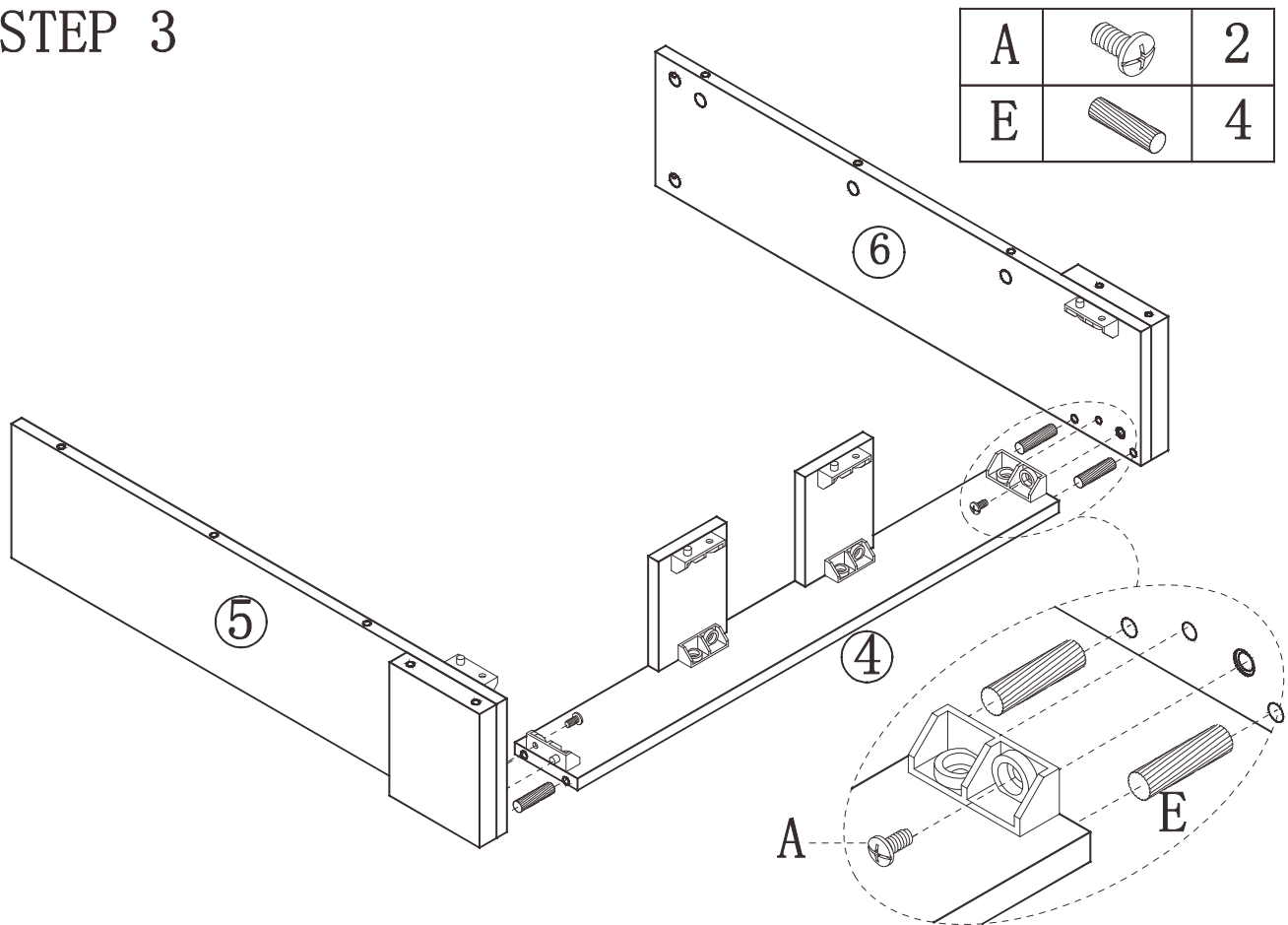

STEP 4

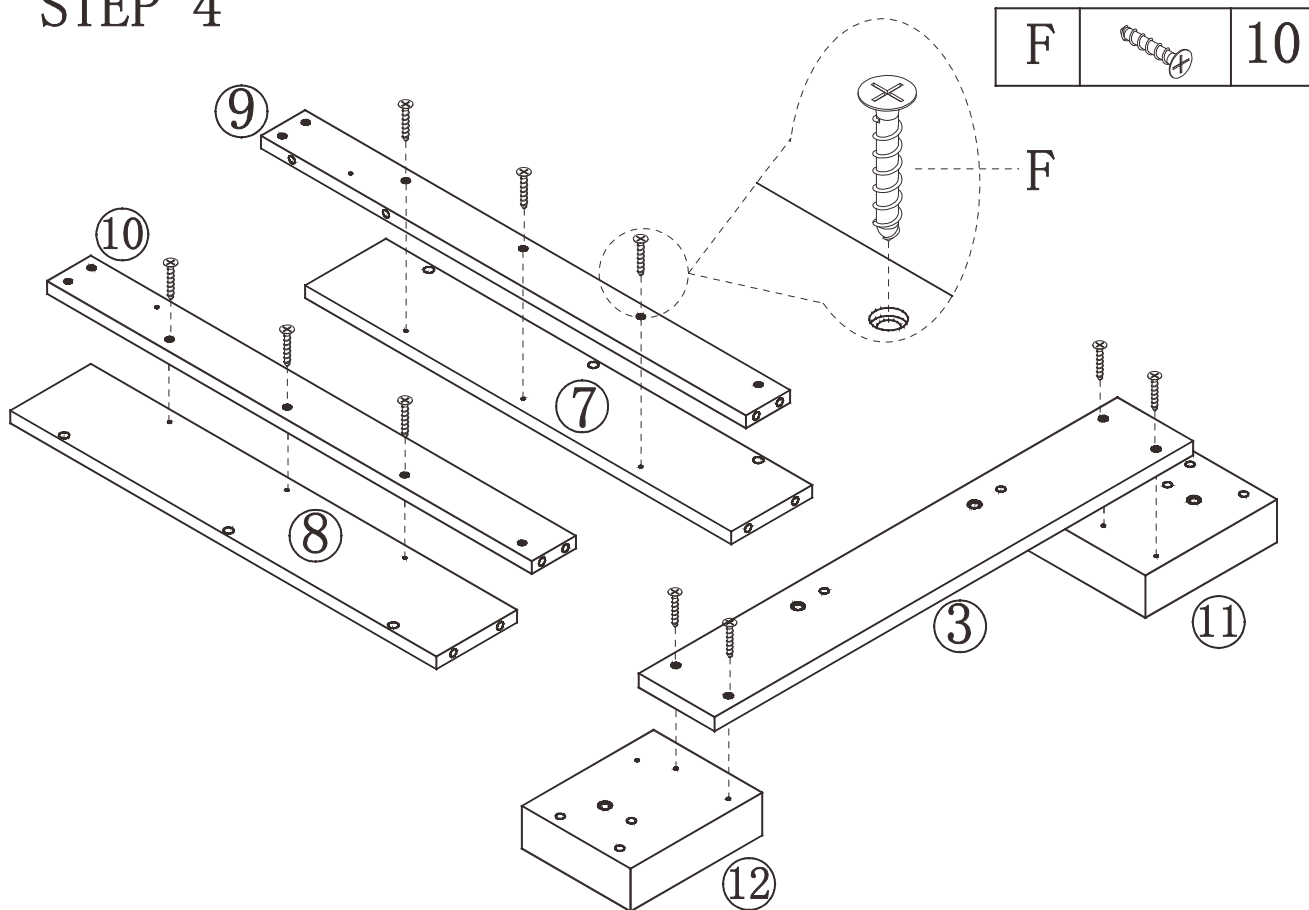

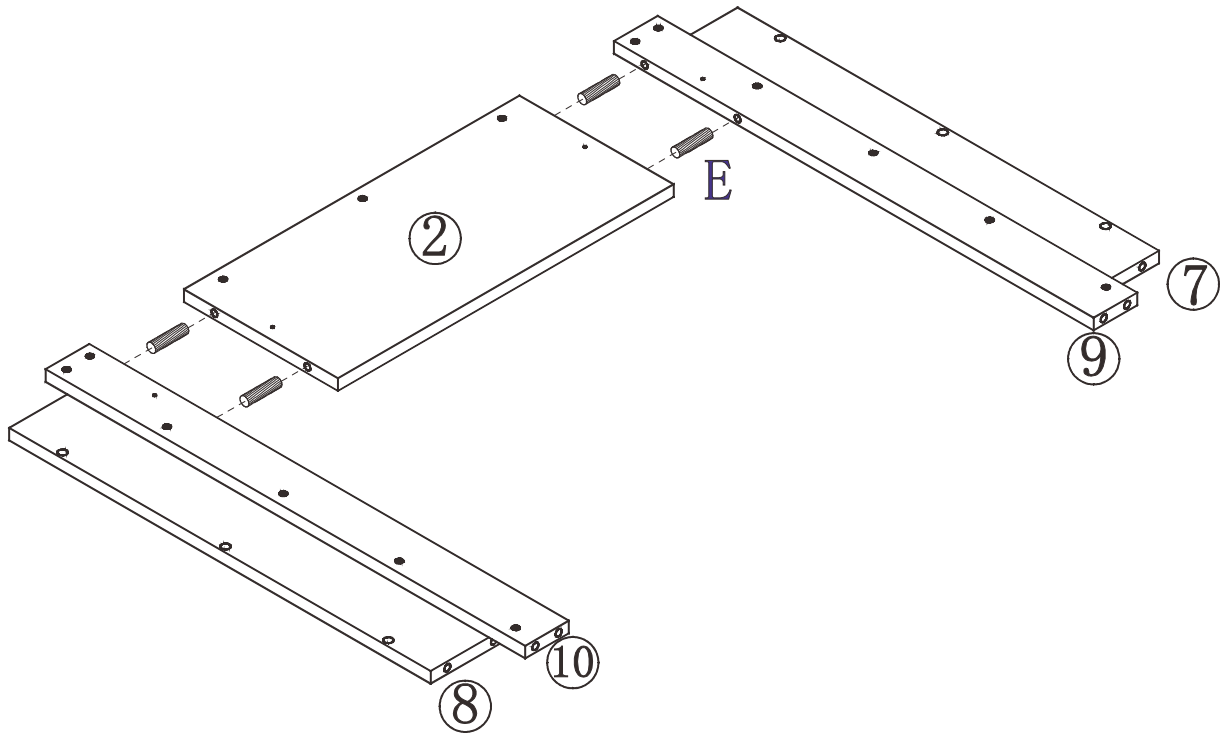

STEP 5

| | | |
|---|---|---|
| E |  | 4 |
|---|---|---|

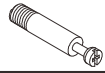

STEP 6

| | | |
|---|---|---|
| C |  | 6 |
| E |  | 8 |

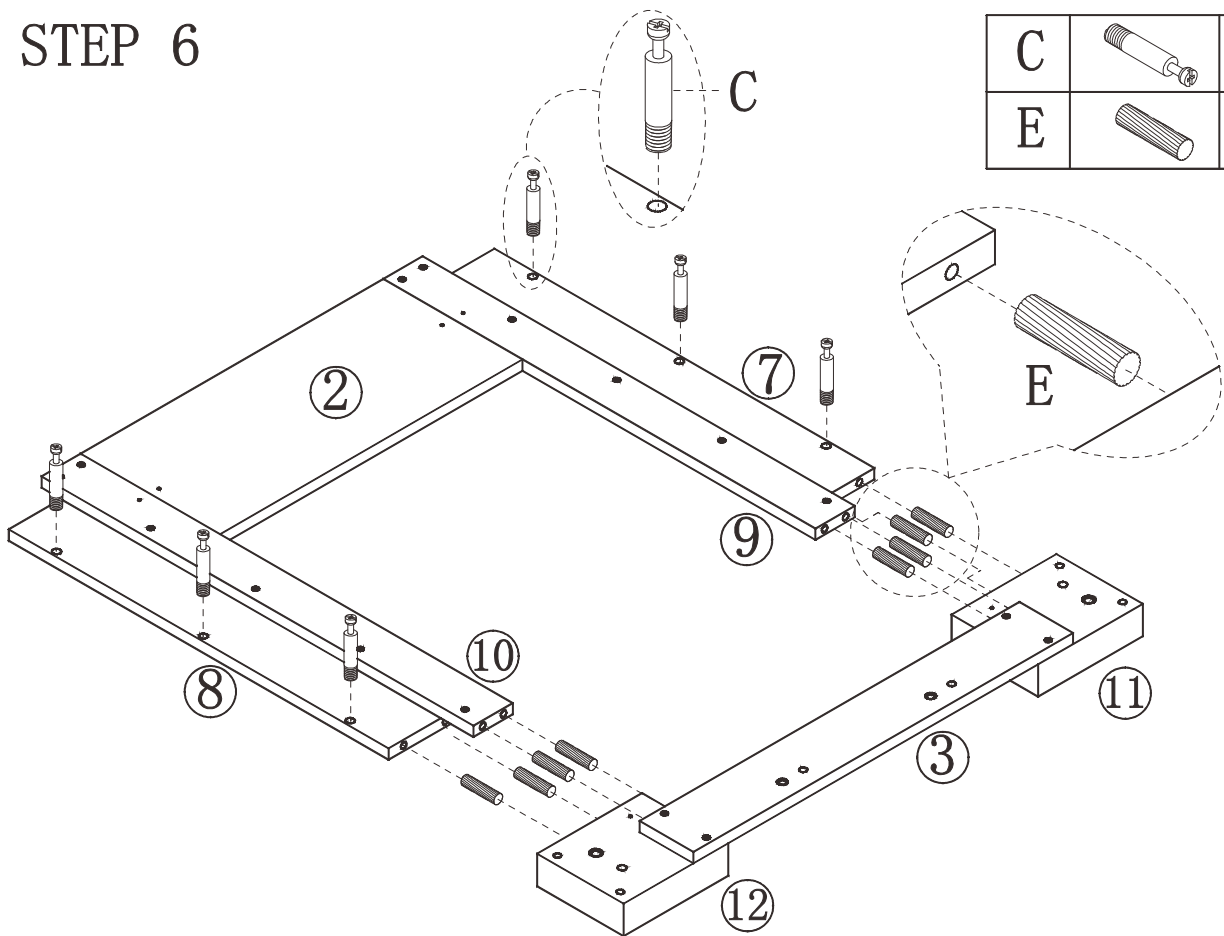



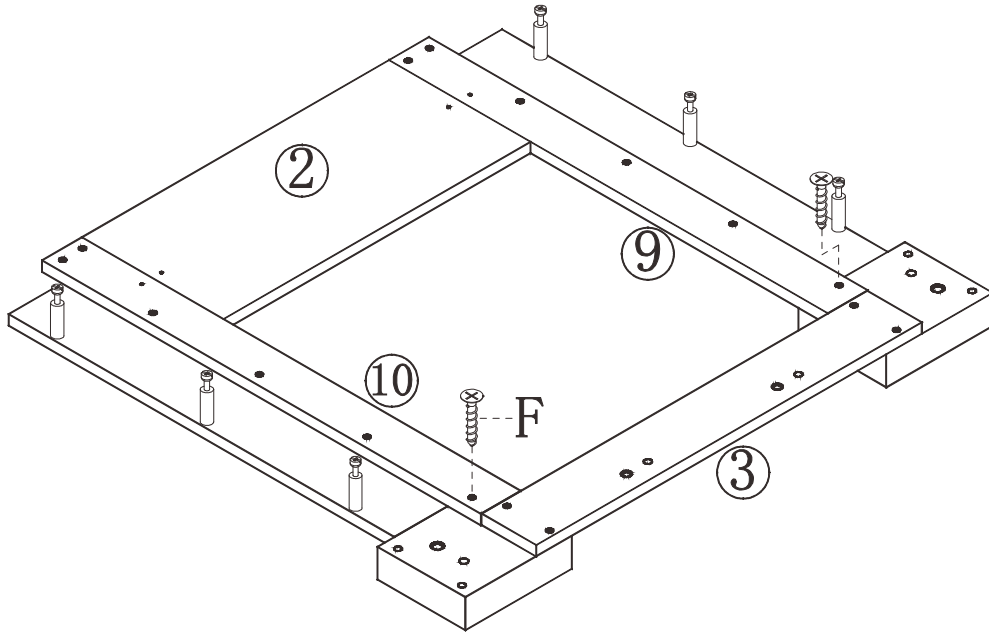

STEP 7

| | | |
|---|---|---|
| F |  | 2 |
|---|---|---|



STEP 8

| | | |
|---|---|---|
| A |  | 4 |
| D |  | 6 |
| E |  | 4 |
| H |  | 6 |

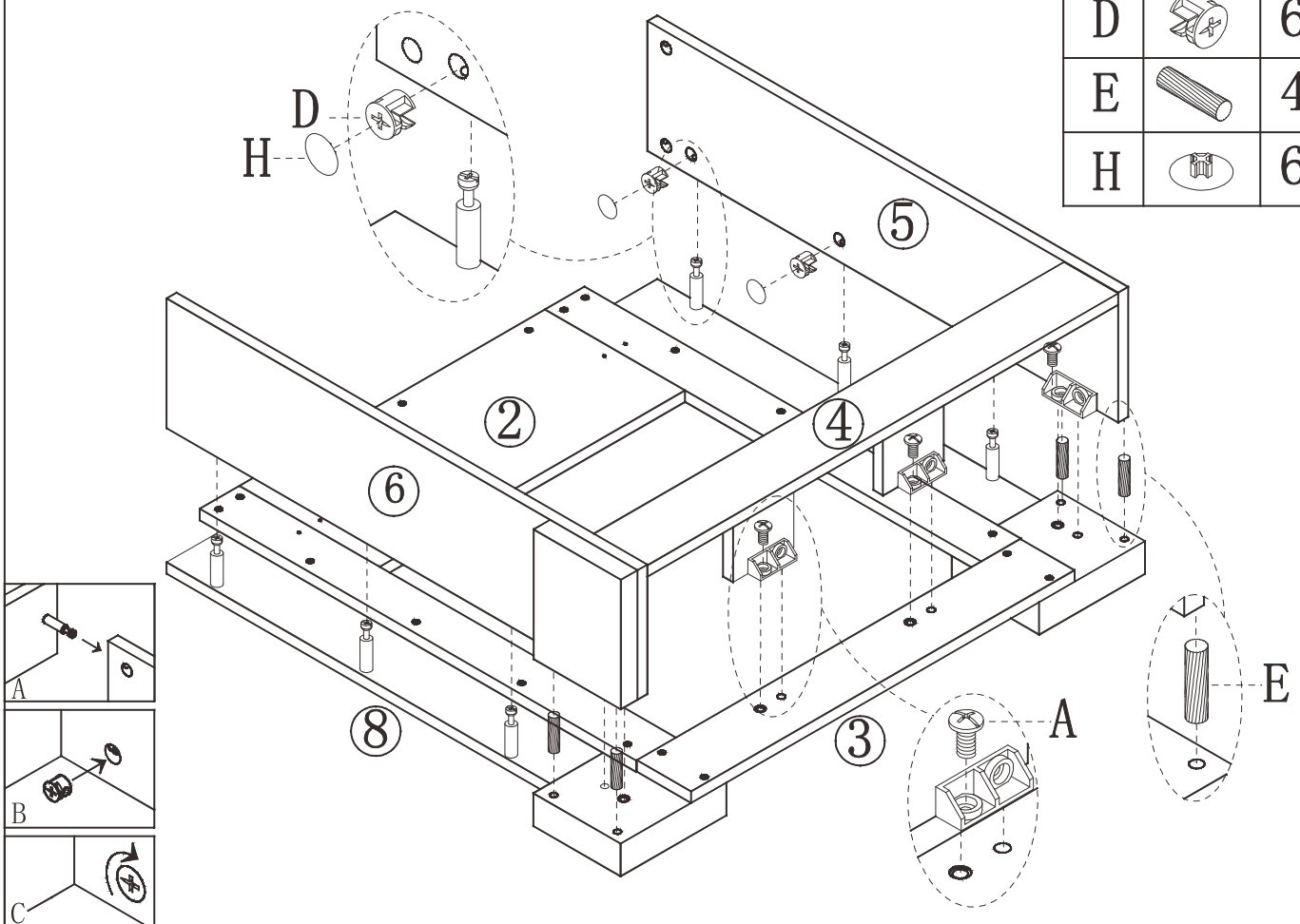

STEP 9

| | | |
|---|---|---|
| G |  | 2 |
|---|---|---|

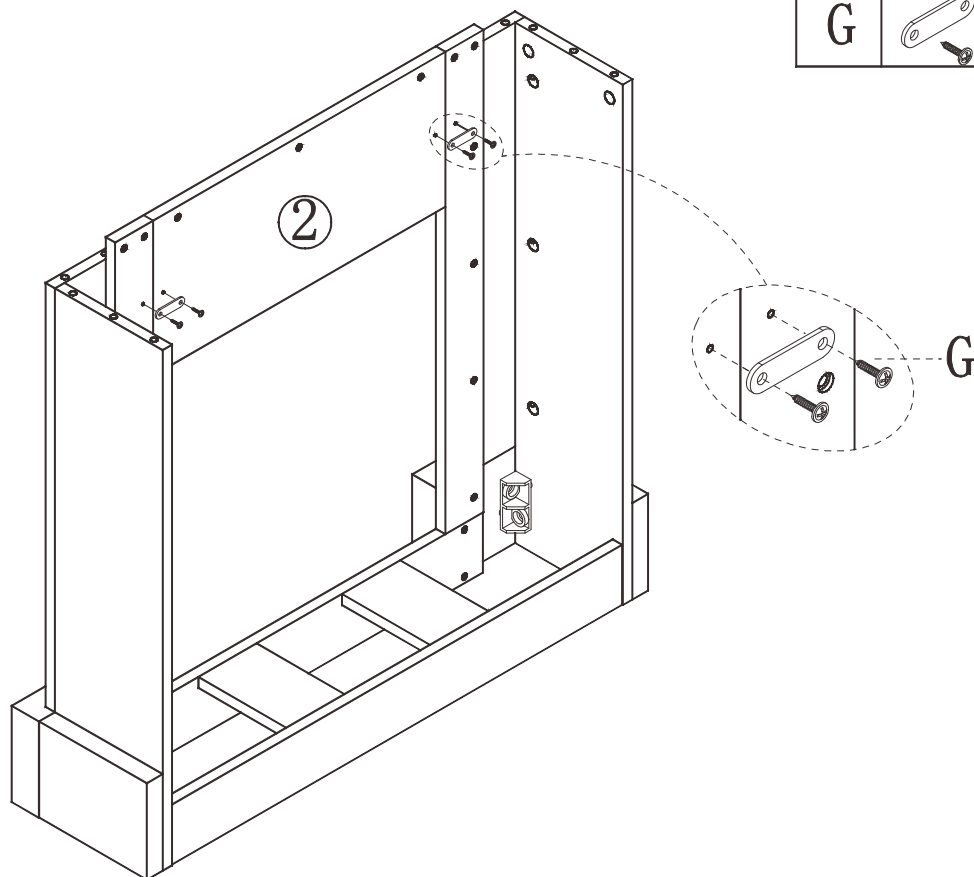



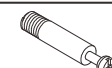

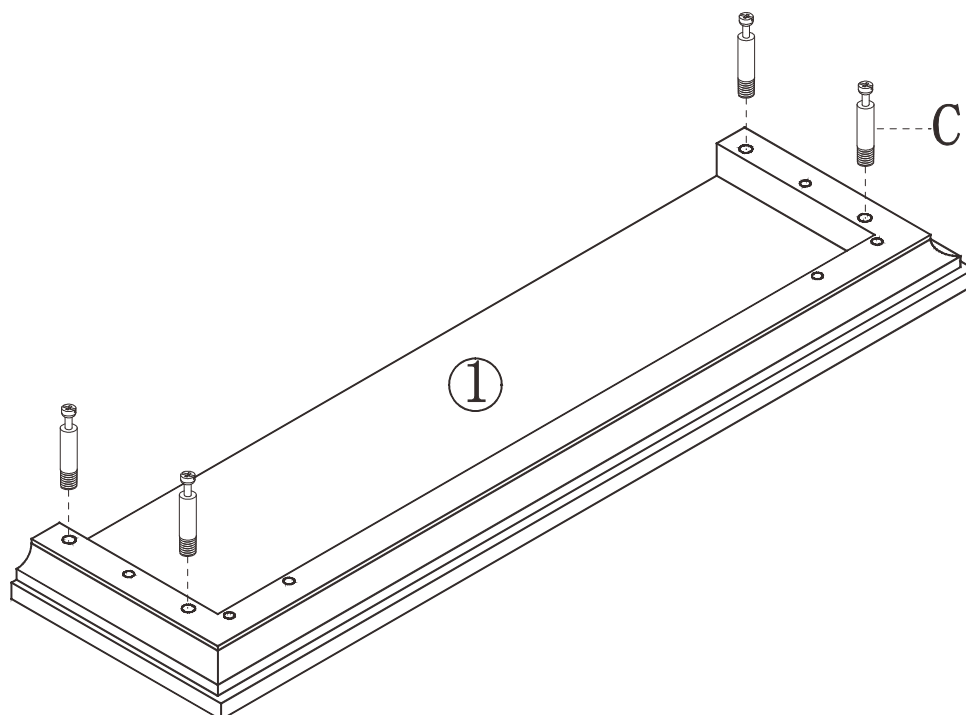
STEP 10

| | | |
|---|---|---|
| C |  | 4 |
|---|---|---|



STEP 11

| | | |
|---|---|---|
| D |  | 4 |
| E |  | 6 |
| F |  | 7 |
| H |  | 4 |

